

FORESIGHT METAL ENGRG PTE LTD

CABLE SUPPORT SYSTEM SPECIALIST & MORE

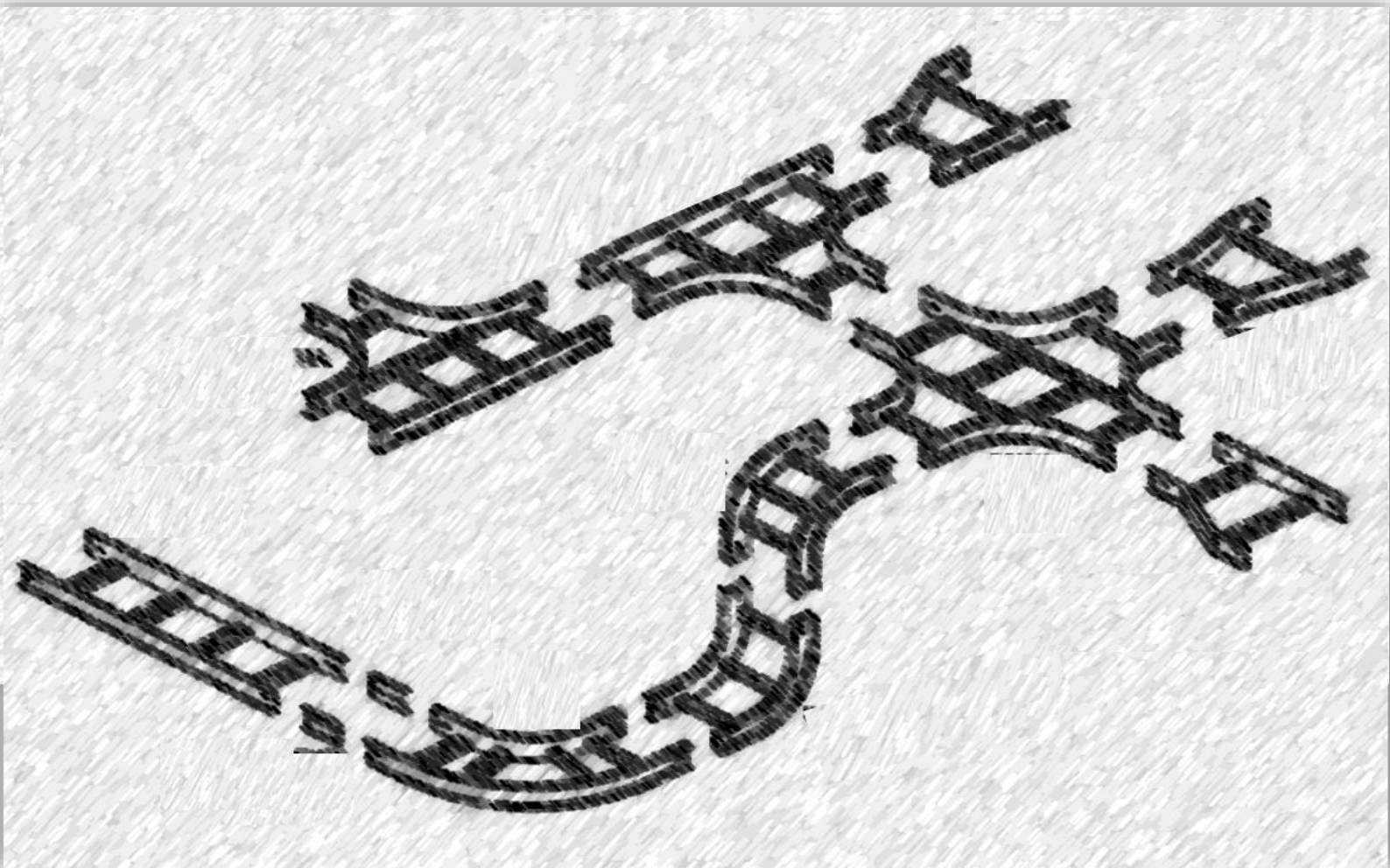

FMETM

ECO-TECH @ SUNVIEW, 1 SUNVIEW ROAD #04-28, 29
SINGAPORE 627615

☎ 6294 8672

☎ 6255 0087

💻 sales@foresight.com.sg

🌐 foresight.com.sg

CO. REG: 199202035R

OFFICE

ECO-TECH @ SUNVIEW,
1 SUNVIEW ROAD
#04-28, 29
SINGAPORE 627615

CONTACT US

TEL: 6294 8672

FAX: 6255 0087

sales@foresight.com.sg

www.foresight.com.sg

PRODUCT OFFERING

METAL CABLE SUPPORT
SYSTEM

- EPOXY FINISHING
- GI FINISHING
- HDG FINISHING
- ZAM FINISHING

CONDUIT FITTING, PIPES
& ACCESSORIES

EARTHING & LIGHTING
PRODUCTS

WIRES

ABOUT US

Since its incorporation in 1992, Foresight Metal Engineering Pte Ltd (FME™) has emerged as one of the top cable support system specialist in Singapore, specializing in metal cable trays, trunkings and ladders for use in commercial and industrial projects. The FME™ brand of cable support system is renowned for its quality and brilliant design, distinguishing itself against competitors and steadily meets or exceeds industry standards.

Leading Production Facilities

FME's™ niche in offering fast and efficient service lies in our strong partnership with local and overseas production facilities that ably support our clients' needs and demands. Our factory facilities' range of state-of-the-art machinery and equipment have enabled FME™ the ability and opportunity to capably supply customized products synonymous with quality and satisfaction.

Large Inventory – Industrial Hardware and Electrical Products

Apart from our main product line of FME™ Metal Cable Support System, FME™ offers more than 8000 hardware and electrical products representing the top line of today's industrial requirements.

Through our wide range of product offering, Foresight Metal Engineering Pte Ltd has much to offer when assisting our clients in meeting their daily operational requirements. Our client portfolio spans across the commercial, marine, medical, pharmaceutical industries, and more.



CO. REG: 199202035R

CABLE SUPPORT SYSTEM SPECIALIST & MORE

OFFICE

ECO-TECH @ SUNVIEW,
1 SUNVIEW ROAD
#04-28, 29
SINGAPORE 627615

CONTACT US

TEL: 6294 8672

FAX: 6255 0087

sales@foresight.com.sg

www.foresight.com.sg

PRODUCT OFFERING

METAL CABLE SUPPORT
SYSTEM

- EPOXY FINISHING
- GI FINISHING
- HDG FINISHING
- ZAM FINISHING

CONDUIT FITTING, PIPES
& ACCESSORIES

EARTHING & LIGHTING
PRODUCTS

WIRES

MAJOR JOB REFERENCES

Foresight Metal Engineering Pte Ltd's (FME™) products have been used in major commercial, industrial and residential projects across Singapore, some of which include leading tourist attractions, educational institutions, and power plants.

2MX Plant @ Jurong Island
Air Trunk Date Centre
Amazon Data Centre
Army Camps – Guillemard, Kranji
CapitaLand Data Centre
Changi Business Centre
China Mobile Int. Data Centre
Chemical Specialist Chemical Plant
Coca Cola Plant
Deutsche Telekom Centre
Exxon Chevron Oil Terminal
Exxon Mobil Refinery
Givaudan
JAC @ Jurong Island
JIPCT
Jurong Water Reclamation Plant
KAP Plant @ Jurong Island
Keppel Merlimau Cogen Power Plant
Kingsland Data Centre
Kranji Water Reclamation Plant
Micron Fab 10A
Micron Fab 10N
Micron Fab 10X
Pulau Tekong Camp
PUB Chestnut Avenue Waterworks
Woodlands Health Campus
Shell Refinery @ Pulau Bukom
Shell Seraya Chemical Plant @
Jurong Island
Siltronic Wafer Fab
Singapore Pools Building - A & A
Singtel Data Centre
SLNG Oil Terminal
SMRT Depot – Bishan, Gali Batu, Seng
Kang
SMRT - Circle Line, Downtown Line,
NSEW Line Upgrading, Thomson Line
SMRT Plant @ Jurong Island
Sungei Gedong Camp
Suntec City A & A
Takasago Warehouse
Tuas Power Plant
Zeon Chemical Plant

National Institute of Education
National University of Singapore
Ngee Ann Polytechnic
Singapore Polytechnic
Singapore General Hospital

Asian Civilisation Museum
Capella Singapore
Capital Tower
Esplanade Theatre on the Bay
Fullerton Hotel
Gardens by The Bay
Hyatt Hotel
ION Orchard
Mandarin Hotel
Marina Bay Financial Centre
Ministry of Home Affairs
Monetary Authority of Singapore
Novena Square
One Marina Boulevard Financial Centre
OUB Centre
Plaza Singapura
Resorts World Sentosa
Singapore International Airport
Singapore Grand Prix F1 Pit Building
Stamford Tyres Building
ST Micron Electronic Building
Telecom Building
Westin Stamford Hotel
Woodlands Health Campus



CABLE TRUNKINGS & ACCESSORIES

FME CABLE SUPPORT SYSTEM

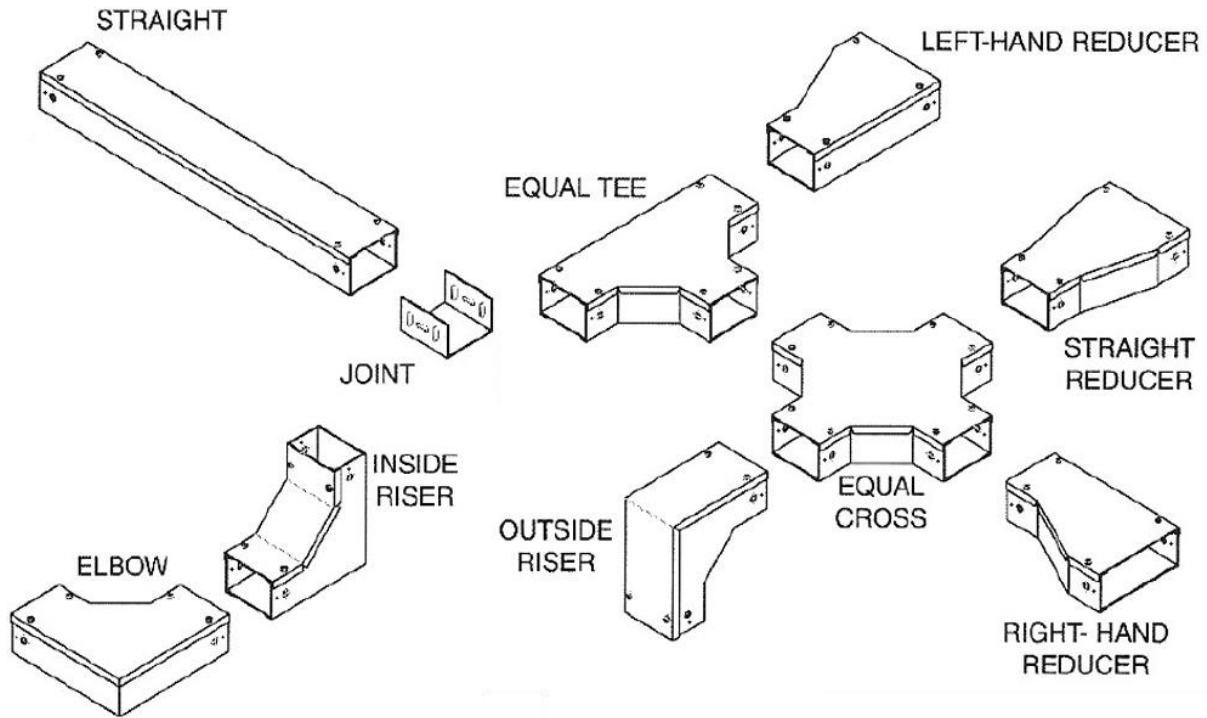

CABLE TRUNKING SYSTEM STANDARD LIST (in mm)

WIDTH (W)	HEIGHT (H)	LENGTH (L)	THICKNESS (T)
50	25	2440	1.0
50	50		
75	50		
100	50		
75	75		
100	75		
150	75		
100	100		
150	100		
200	100		
250	100	2.0	
300	100		

FINISHING

- 1 EPOXY POWDER COATED
- 2 HOT DIPPED GALVANIZING (BS:EN:ISO1461:2009)
- 3 HOT DIPPED GALVANIZING & EPOXY POWDER COATED
- 4 ZAM COATED - ZINC-ALUMINIUM-MAGNESIUM PROTECTIVE COATING
- 5 ANODIZED (FOR ALUMINIUM ONLY)

MATERIALS

- 1 HOT / COLD ROLLED STEEL
- 2 ELECTRO GALVANIZED STEEL TO BS 1449 PART 1
- 3 PRE GALVANIZED STEEL
- 4 STAINLESS STEEL AISI 304, 316
- 5 ALUMINIUM AA1100 OR 5052-H32, 60131-75

CABLE TRUNKINGS & ACCESSORIES

FME CABLE SUPPORT SYSTEM

TKE1B
45DEG ELBOW

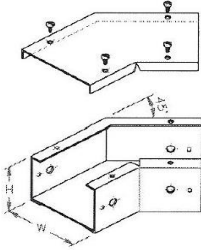

TKE2B
90DEG ELBOW

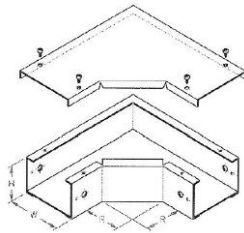

TKEQT
EQUAL TEE

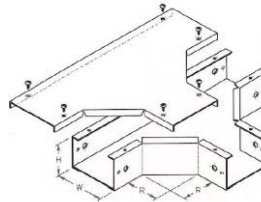

TKEQX
EQUAL CROSS

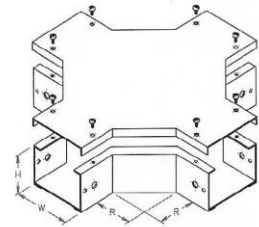

TKO1R
45DEG OUTSIDE RISER

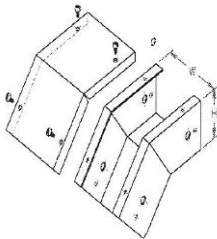

TKO2R
90EG OUTSIDE RISER

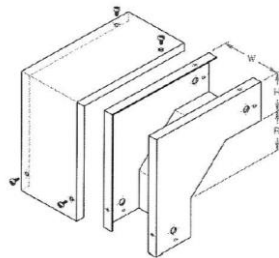

TKI1R
45DEG INSIDE RISER

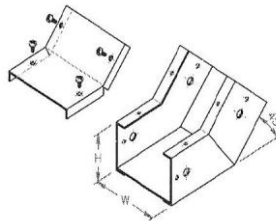

TKI2R
90DEG INSIDE RISER

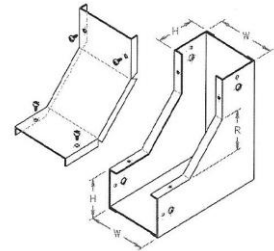

TKSRR
STRAIGHT REDUCER

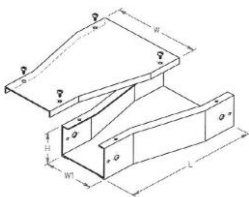

TKLRR
LEFT HAND REDUCER

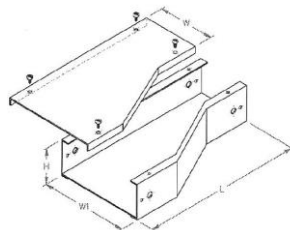

TKRRR
RIGHT HAND REDUCER

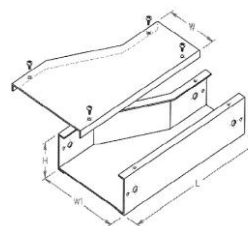

TKUJT
TRUNKING JOINT

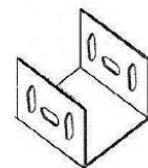

CABLE TRAYS & ACCESSORIES

FME CABLE SUPPORT SYSTEM

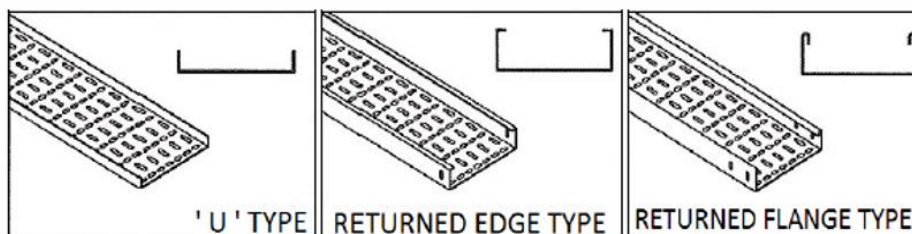
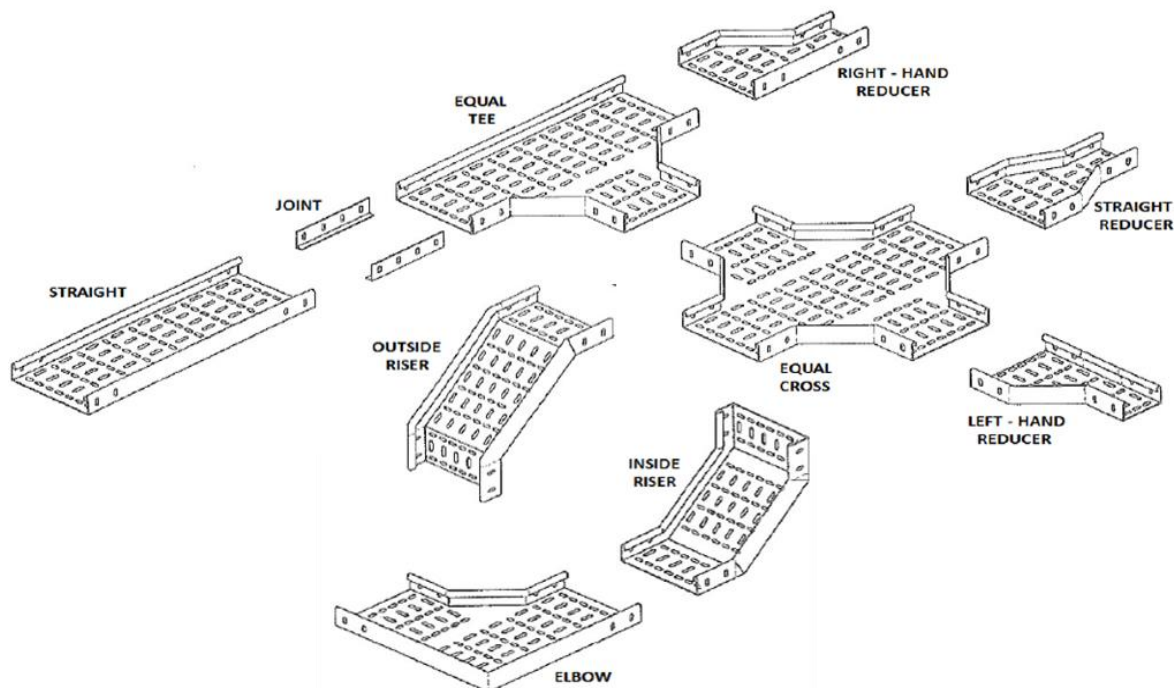

CABLE TRAY SYSTEM STANDARD LIST (in mm)

WIDTH (W)	HEIGHT (H)	LENGTH (L)	THICKNESS (T)
50			
75			
100			
150	15		
200	20		
300	25		1.0
400	50	2440	1.2
450	100	3000	1.5
500	125		1.6
600	150		2.0
700	200		
800			
900			
1000			
1200			

FINISHING

- 1 EPOXY POWDER COATED
- 2 HOT DIPPED GALVANIZING (BS:EN:ISO1461:2009)
- 3 HOT DIPPED GALVANIZING & EPOXY POWDER COATED
- 4 ZAM COATED - ZINC-ALUMINIUM-MAGNESIUM PROTECTIVE COATING
- 5 ANODIZED (FOR ALUMINIUM ONLY)

MATERIALS

- 1 HOT / COLD ROLLED STEEL
- 2 ELECTRO GALVANIZED STEEL TO BS 1449 PART 1
- 3 PRE GALVANIZED STEEL
- 4 STAINLESS STEEL AISI 304, 316
- 5 ALUMINIUM AA1100 OR 5052-H32, 60131-75

CABLE TRAYS & ACCESSORIES

FME CABLE SUPPORT SYSTEM

TFE1B
45DEG ELBOW
(CURVE RADIUS)

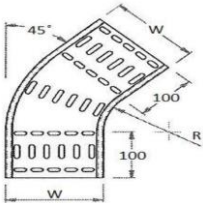

TFE1B
45DEG ELBOW
(STRAIGHT RADIUS)

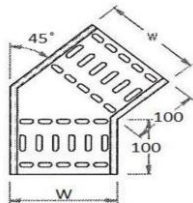

TFE2B
90DEG ELBOW
(CURVE RADIUS)

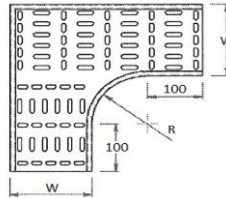

TFE2B
90DEG ELBOW
(STRAIGHT RADIUS)

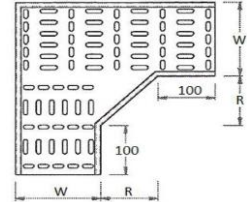

TFEQT
EQUAL TEE
(CURVE RADIUS)

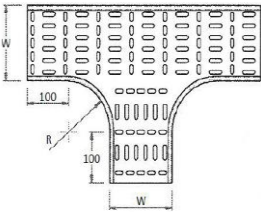

TFEQT
EQUAL TEE
(STRAIGHT RADIUS)

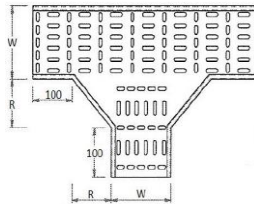

TFEQX
EQUAL CROSS
(CURVE RADIUS)

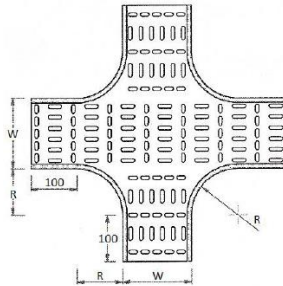

TFEQX
EQUAL CROSS
(STRAIGHT RADIUS)

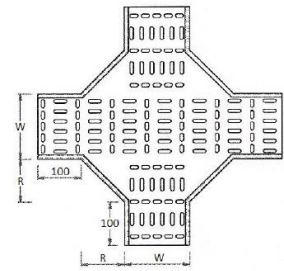

TFSR
STRAIGHT REDUCER

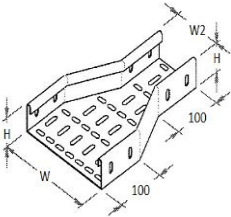

TFLRR
LEFT HAND REDUCER

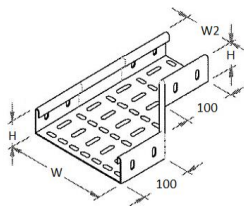

TFRRR
RIGHT HAND REDUCER

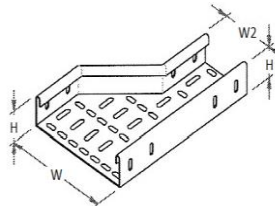

TFI2R
90DEG INSIDE RISER
(CURVE RADIUS)

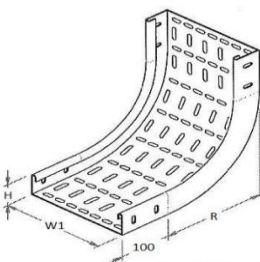

TFI2R
90DEG INSIDE RISER
(STRAIGHT RADIUS)

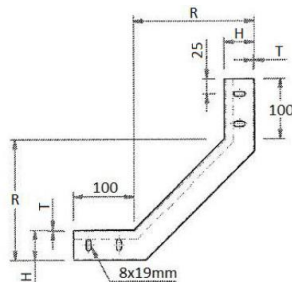

TFO2R
90DEG OUTSIDE RISER
(CURVE RADIUS)

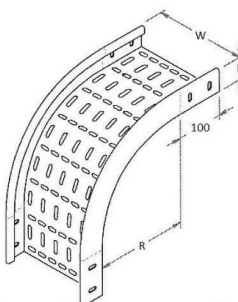

TFO2R
90DEG OUTSIDE RISER
(STRAIGHT RADIUS)

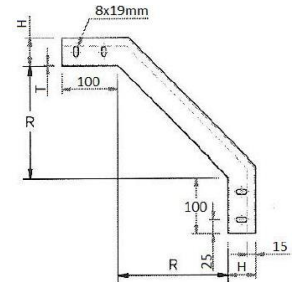

CABLE LADDERS & ACCESSORIES

FME CABLE SUPPORT SYSTEM

The diagram illustrates various cable ladder accessories: STRAIGHT, STRAIGHT JOINT, UNEQUAL TEE, EQUAL TEE, ELBOW (two types), OUTSIDE RISER, INSIDE RISER, EQUAL CROSS, LEFT - HAND REDUCER, STRAIGHT REDUCER, and RIGHT - HAND REDUCER. Below the main diagrams are five detailed views of rail connections: OUTSIDE RAIL TYPE WELDED ON TYPE, KNOCK DOWN TYPE WELDED ON TYPE Z-TYPE, INSIDE RAIL TYPE WELDED ON TYPE, KNOCK DOWN TYPE SCREWED ON TYPE Z-TYPE, and KNOCK DOWN TYPE SCREWED ON TYPE.

CABLE LADDER SYSTEM STANDARD LIST (in mm)				FINISHING
WIDTH (W)	HEIGHT (H)	LENGTH (L)	THICKNESS (T)	
100				1 EPOXY POWDER COATED
150				2 HOT DIPPED GALVANIZING (BS:EN:ISO1461:2009)
200				3 HOT DIPPED GALVANIZING & EPOXY POWDER COATED
300				4 ZAM COATED - ZINC-ALUMINIUM-MAGNESIUM PROTECTIVE COATING
400				5 ANODIZED (FOR ALUMINIUM ONLY)
450	100			MATERIALS
500	125	2440		1 HOT / COLD ROLLED STEEL
600	150	3000	2.0	2 ELECTRO GALVANIZED STEEL TO BS 1449 PART 1
700	200			3 PRE GALVANIZED STEEL
800				4 STAINLESS STEEL AISI 304, 316
900				5 ALUMINIUM AA1100 OR 5052-H32, 60131-75
1000				
1200				

CABLE LADDERS & ACCESSORIES

FME CABLE SUPPORT SYSTEM

LIE2B (I/R TYPE)
LZE2B (Z TYPE)
LOE2B (O/R TYPE)
90DEG ELBOW
(CURVE RADIUS)

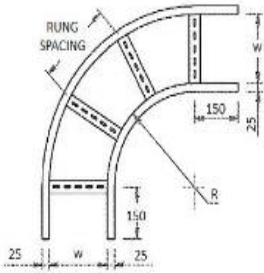

LIE1B (I/R TYPE)
LZE1B (Z TYPE)
LOE1B (O/R TYPE)
45DEG ELBOW
(CURVE RADIUS)

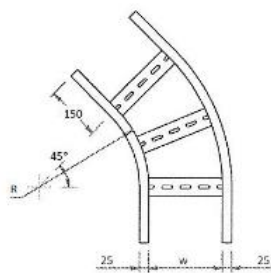

CSTM FAB
30DEG ELBOW
(CURVE RADIUS)

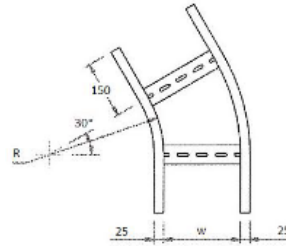

LIEQX (I/R TYPE)
LZEQX (Z TYPE)
LOEQX (O/R TYPE)
90DEG EQUAL CROSS

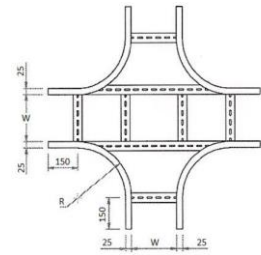

LIEQT (I/R TYPE)
LZEQT (Z TYPE)
LOEQT (O/R TYPE)
90DEG EQUAL TEE

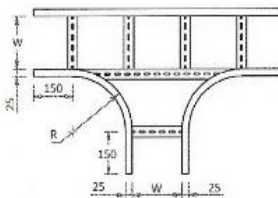

LISRR (I/R TYPE)
LZSRR (Z TYPE)
LOSRR (O/R TYPE)
STRAIGHT REDUCER

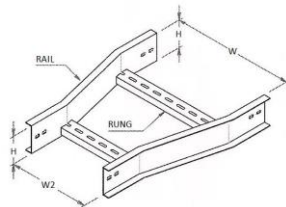

LILRR (I/R TYPE)
LZLRR (Z TYPE)
LOLRR (O/R TYPE)
LEFT-HAND REDUCER

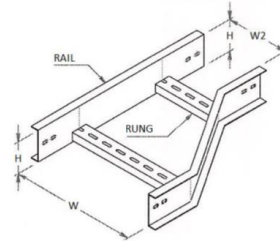

LIRRR (I/R TYPE)
LZRRR (Z TYPE)
LORRR (O/R TYPE)
RIGHT-HAND REDUCER

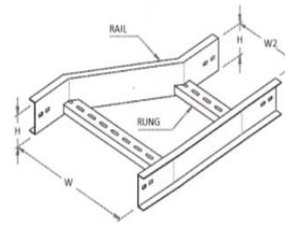

LIRI2 (I/R TYPE)
LZRI2 (Z TYPE)
LORI2 (O/R TYPE)
90DEG INSIDE RISER

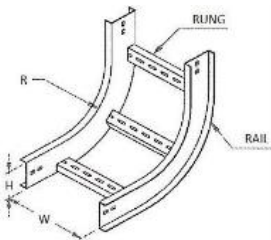



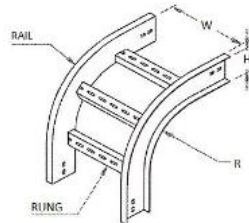

LIRO2 (I/R TYPE)
LZRO2 (Z TYPE)
LORO2 (O/R TYPE)
90DEG OUTSIDE RISER

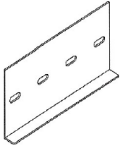
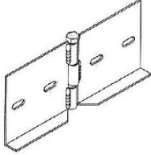
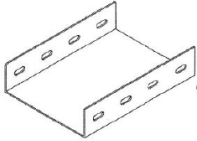
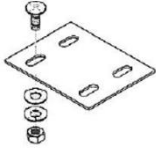
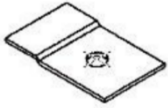
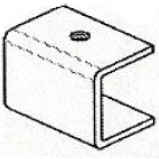
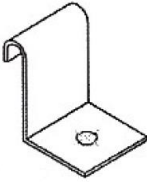
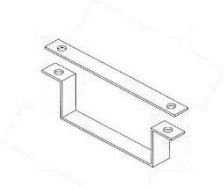
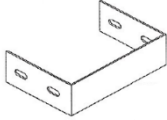
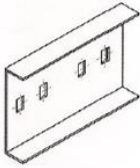
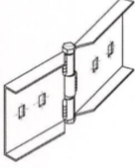
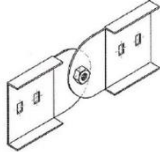
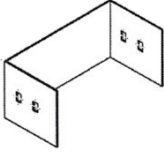
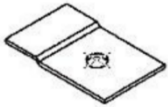
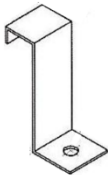
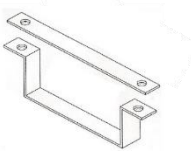

CABLE FASTENERS

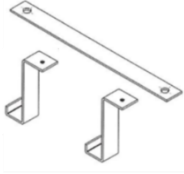
FME CABLE SUPPORT SYSTEM

CABLE TRAY				
STRAIGHT JOINT	HORIZONTAL JOINT	U JOINT	FISH PLATE JOINT	HOLD DOWN CLIP
				
'C' COVER CLAMP	HOLD DOWN CLAMP	WRAP-OVER CLAMP	END PLATE	
				
CABLE LADDER				
STRAIGHT JOINT	HORIZONTAL JOINT	VERTICAL JOINT	END PLATE	HOLD DOWN CLIP
				
HOLD DOWN CLAMP	WRAP-OVER CLAMP	'C' COVER CLAMP	'Z' COVER CLAMP	'G' COVER CLAMP
				



PSB Singapore

CERTIFICATE OF CONFORMITY

No. CLS2N 108949 0001 Rev. 00

Initial No. -

Certificate Holder: **FORESIGHT METAL ENGINEERING PTE LTD**
1 Sunview Road
#04-29 Eco-Tech @ Sunview
SINGAPORE 627615
SINGAPORE

UEN - 199202035R

Product: Steel surface cable trunkings and accessories

Brand Name: FME

Model(s): (i) TKSTTECO0202108 (ii) TKSTTECO0402128
(iii) TKSTTECO0404148 (iv) TKSTTECO0604148

Product Details: Type of steel of the trunking : Electroplated Galvanised Steel
Colour : Orange
Classification : Class 1
Length : 2.44m

Nominal external size (mm)	Nominal body thickness (mm)	Nominal cover thickness (mm)
50(W)x50(H)	1.0	1.0
100(W)x50(H)	1.2	1.2
100(W)x100(H)	1.4	1.2
150(W)x100(H)	1.4	1.2

Standard(s): SS 249:1981 (2012)

Country of Origin: Malaysia

Test Report(s): 7191128186-EEC15/02-SYG, 7191128186-CHM15/02A-PGK(EEC)

Valid until: 2025-07-23

Page 1 of 1

Issued on: 2020-07-28

Vice-President (Certification Department)
TÜV SÜD PSB

This Certificate is the property of TÜV SÜD PSB Pte Ltd. Reports listed in this certificate is an integral part of the certificate and should be read in conjunction with it. The use of this Certificate is subjected to TÜV SÜD Group Testing and Certification Regulations; TÜV SÜD PSB Pte Ltd (PSB) General Terms and Conditions of Business and PSB Product Listing Scheme (PLS) Application Fact Sheet. The manufacturer is solely responsible for compliance of any product that has the same designation as the product type-tested. Persons relying on this Certificate should verify its validity by checking the e-directory: www.tuvsud.com/ps-cert. For more information on TÜV SÜD PSB Pte Ltd product certification: www.tuv-sud-psb.sg

TÜV SÜD PSB Pte Ltd • 1 Science Park Drive • Singapore 118221

TUV®

TEST REPORT: 7191128186-CHM15/02A-PGK(EEC)

Date: 19 FEB 2016

Tel: +65 68851322 Fax: +65 67784301

Client's Ref:

Email: tai-hoe.lin@tuv-sud-psb.sg

Note: This report is issued subject to the Testing and Certification Regulations of the TÜV SÜD Group and the General Terms and Conditions of Business of TÜV SÜD PSB Pte Ltd. In addition, this report is governed by the terms set out within this report.



PSB Singapore

Choose certainty.
Add value.

SUBJECT

Type Testing of Cable Trunking and Accessories

CLIENT

Foresight Metal Engineering Pte Ltd
Blk 27 Jalan Berseh,
#01-108
Singapore 200027

SAMPLE SUBMISSION DATE

27 Jan 2016

DATE TEST CONDUCTED

03 Feb to 05 Feb 2016

DESCRIPTION OF SAMPLE

One sample of coated cable trunking comprising bidders, covers, connectors, screws, nuts and washers, was submitted by the above client to the Electrical & Electronics Centre of TÜV SÜD PSB Pte Ltd.

Brand : "FME"

Colour : Orange



TÜV SÜD PSB

Laboratory:
TÜV SÜD PSB Pte. Ltd.
No.1 Science Park Drive
Singapore 118221

Phone: +65-6885 1333
Fax: +65-6776 8670
E-mail: testing@tuv-sud-psb.sg
www.tuv-sud-psb.sg
Co. Reg: 199002667R

Regional Head Office:
TÜV SÜD Asia Pacific Pte. Ltd.
1 Science Park Drive, #02-01
Singapore 118221
TUV®

**RESULTS**Resistance to Continuous Salt Spray Test

Component	"FME" Orange	SS 249 : 1981 (2012) Requirements
	Visual appearance after 48 hours exposure	
Body (3 units)	No rusting on all tested surfaces	Screw threads, interior long bend edges and cut edges shall not show more than 15% (by area) of rusting. All other areas shall not show more than 0.1% (by area) of rusting.
Cover (3 units)	No rusting on all tested surfaces	
Connector (3 units)	No rusting on all tested surfaces	
Self-tapping Screws (10 units)	No rusting on all tested units	
Screws (10 units)	No rusting on all tested units	
Nuts (10 units)	No rusting on all tested units	
Flat Washers (10 units)	No rusting on all tested units	
Split lock washers (10 units)	No rusting on all tested units	

Resistance to Scratches

Component	"FME" Orange	SS 249 : 1981 (2012) Requirement
Trunking	Passed	Shall withstand a load of 800g

Remark : Characteristic tested on the above sample was found to have complied with SS 249 : 1981 (2012) Clause 9 & 11 requirements.

MS PECK GEOK KHOON
TECHNICAL EXECUTIVE

MRS WONG-LIN TAI HOE
SENIOR CONSULTANT
COATINGS
CHEMICAL & MATERIALS

CONDUIT PIPES

CABLE SUPPORT SYSTEM– VOLTECX CONDUIT PIPES

BS4568: PART 1: 1970 (CLASS 4) RIGID CONDUIT

- Heavy protection on the interior and exterior of conduit surface.
- Hot-Dipped Galvanized to BS EN ISO 1461 (Class 4)
- Supplied with one coupler and threaded at both ends.
- Heavy Gauge Metric size threaded
- Suitable for outdoor installation and places where there's high level of corrosion, chemical plants, and in areas of high humidity

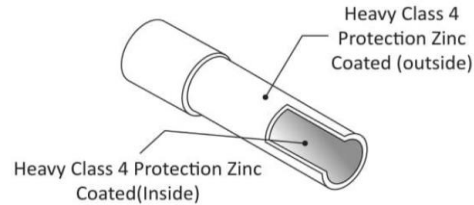

Nominal size	Outside Diameter		Nominal Wall Thickness	Length of Threads		Weight per Length
	Min	Max		Min	Max	
20mm	19.7mm	20.0mm	1.6+- 0.15mm	13.0	15.0	+2.9kg
25mm	24.6mm	25.0mm	1.6+- 0.15mm	16.0	18.0	+3.8kg
32mm	31.6mm	32.0mm	1.6+- 0.15mm	18.0	20.0	+5.5kg

Note: Standard length 3.75mtr (w/o coupler)

: Colored, epoxy powder coated conduits supplied upon request

BS4568: PART 1: 1970 (CLASS 3) RIGID CONDUIT

- Medium protection on the interior and exterior of conduit surface.
- Supplied with one coupler and threaded at both ends.
- Heavy Gauge Metric size threaded
- Suitable for indoor and semi-indoor installation

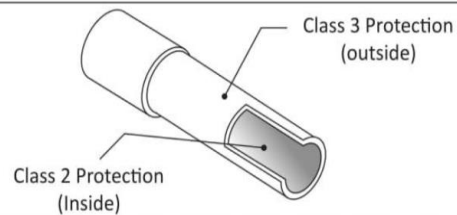

Nominal size	Outside Diameter		Nominal Wall Thickness	Length of Threads		Weight per Length
	Min	Max		Min	Max	
20mm	19.7mm	20.0mm	1.6+- 0.15mm	13.0	15.0	+2.7kg
25mm	24.6mm	25.0mm	1.6+- 0.15mm	16.0	18.0	+3.4kg
32mm	31.6mm	32.0mm	1.6+- 0.15mm	18.0	20.0	+4.5kg

Note: Standard length 3.75mtr (w/o coupler)

: Colored, epoxy powder coated conduits supplied upon request

BS31: 1940 (CLASS 3) RIGID CONDUIT

- Medium protection on the interior and exterior of conduit surface.
- Supplied with one coupler and threaded at both ends.
- Heavy Gauge Imperial size threaded
- Suitable for indoor and semi-indoor installation

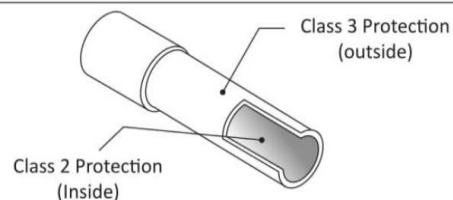

Nominal size	Outside Diameter		Nominal Wall Thickness	Length of Threads		Weight per Length
	Min	Max		Min	Max	
¾"	18.8mm	19.1mm	1.6+- 0.15mm	13.0	15.0	+2.7kg
1"	25.1mm	25.4mm	1.6+- 0.15mm	16.0	18.0	+3.4kg
1 ¼"	31.5mm	31.8mm	1.6+- 0.15mm	18.0	20.0	+4.5kg

Note: Standard length 3.75mm (w/o coupler)

: Colored, epoxy powder coated conduits supplied upon request

CONDUIT PIPES

CABLE SUPPORT SYSTEM – VOLTECX CONDUIT PIPES

Commercial Projects/ Mixed Development/ Hotels:	Consultants	Year
• 70 Lavender Street Commercial		2016
• 2HR @ Former Appollo Center/ Havelock Road		2015-2016
• AXA Tower A&A (3rd to 6th & 8th to 52nd Stories) (BMS Services)	Squire Mech Pte Ltd	2017-
• Bugis Junction A&A		2015-2016
• Big Box @ Jurong East		2015
• Borneo Motors @ Pandan Crescent		2016-2017
• City Gate Mixed Development (with 311 units Condo and 100+ Units shopping)	William Ng Consultants Pte Ltd	2017
• Changi Staging Ground		2016
• Centennial Towers A&A		2015
• Crater Lake @ Science Park	J Roger Preston	2017-
• Employment and Employability Insitute, 141 Redhill Road		2014-2015
• Hotel Indigo/ Holiday Inn Hotel @ Katong 883	United Project Consultants Pte Ltd	2014-2015
• Hillion Shopping Mall @ Bukit Panjang		2015-2017
• Metropolis Tower A (Tennancy Works)		2015
• Mediacorp/ Security Services		2015
• Mizhuho Bank @ UE Bizhub (East)		2015-2016
• MND A&A		2015
• Ministry of Foreign Affairs @ Sherwood Road, New 3 Stories Building	J Roger Preston	2017-
• OUE Downtown @ 6 Shenton Way A&A		2016-
• Premier Inn Hotel @ Beach Road		2014-2015
• Park Mall @ Dhoby Ghaut	Parsons	2017-
• Raffles Hotel A&A	Beca Carter Hollings & Ferner (S.E.Asia) Pte Ltd	2017-
• Soo Kee Jewellery HQ @ Changi South	Bescon Consulting Engineers Pte Ltd	2015
• Simei Shopping Center A&A		2014-2015
• Schneider HQ @ Kallang		2017
• Stamford Arts Center		2017-
• Various Markets Upgrading Projects		2017-
• Woods Square @ Woodlands	Alpha Consulting Engineers Pte Ltd	2017-
Social/ Army Camps/ Govt/ Healthcare/ Transport		
• CMPB/ Depot Road A&A Tower A		2015
• Changi Hospital Phase 2 New Blk (BMS and AMCV)		2016-
• Canberra MRT Station	LTA	2017-
• Downtown Line Stage 3 (DTL3) C929		2016
• Downtown Line Stage 3 (DTL3) C932A		2017
• DSO @ Science Park	Parsons	2015-2016
• DSTA @ Deport Road	DSTA/ Rakine and Hill	2016-
• Gospel Light Christian Church (Punggol)		2015-2016
• Hougang Nursing Home		2015-2016
• Hampshire LTA Office A&A		2017-
• Kranji Camp A&A		2017-
• Kranji Detention Camp @ Lorong Lorbaski		2016-
• Mandai Camp A&A		2017-
• Margaret Drive Nursing Home		2015-2016
• Nee Soon Camp 15 Blks New and A&A	William Ng	2015-
• Paya Lebar Airspace A&A		2015
• Pasir Lebar Camp A&A		2016
• Right To Walk / Various MRT and Island Wide Linkways		2015-
• SMRT/ Wireless/ NCS IT190		2014-2015
• Seng Kang Hospital (Elect/ ELV/ and 6 other major services)	Parsons	2015-
• Selarang Camp 3 New Blocks		2014-2016
• Selarang Prisons (Data Services)	Surbana	2017-
• Seletar Camp 15 Blks New and A&A	Gimms	2015-
• Sembawang Camp A&A		2015-2016
• Sembawang Airbase A&A		2015
• Seng Kang Bus Interchange		2016
• Seng Kang/ Punggol LRT A&A		2016-
• Yishun Community Hospital (Security Services)	CPG	2015-2016
• Yishun Bus Interchange		2014-2015
• Various Army Camps A&A		

UNISTRUT CHANNELS

CABLE SUPPORT SYSTEM

STRAIGHT UNISTRUT
UNISTTHDG41413M
UNISTTHDG41416M

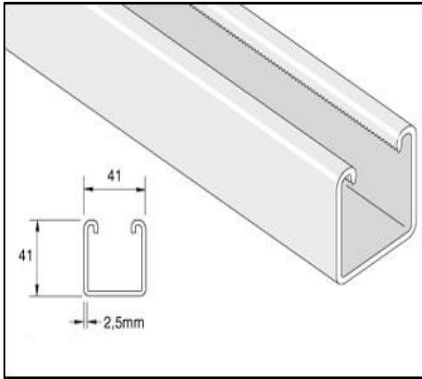

SLOTTED UNISTRUT
UNISTSHDG41413M
UNISTSHDG41416M

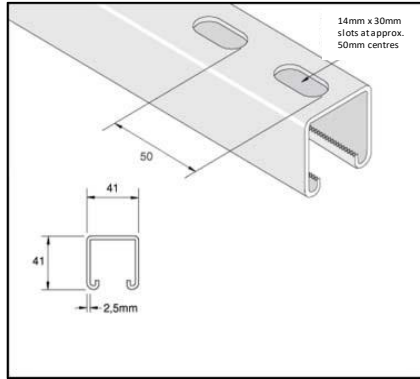

BACK-TO-BACK UNISTRUT
UNIB2BHDG41413M
UNIB2BHDG41416M

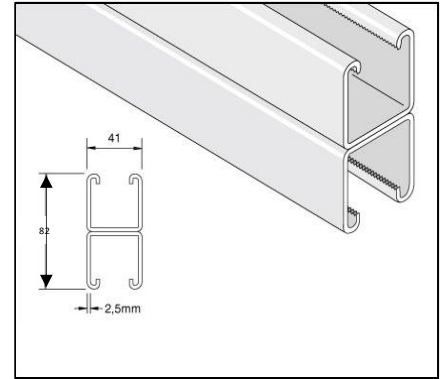

STRAIGHT UNISTRUT
UNISTTHDG41213M
UNISTTHDG41216M

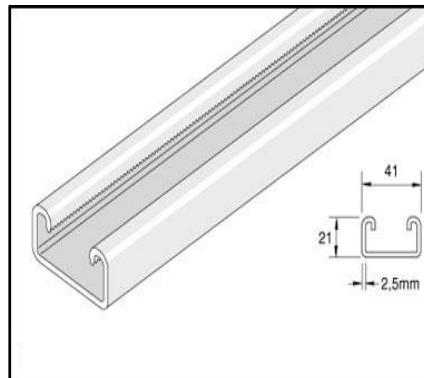

SLOTTED UNISTRUT
UNISTSHDG41213M
UNISTSHDG41216M

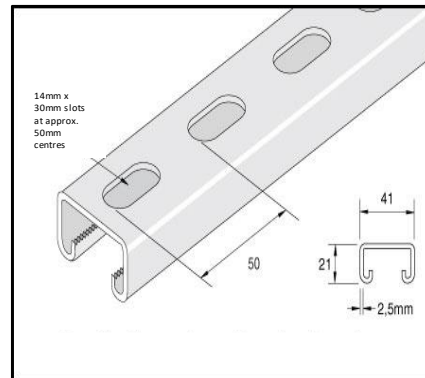

BEAM SPAN / UNSUPPORTED COLUMN (mm)	CHANNEL	MAX. LOAD (kg)	DEFLECTION AT MAX. ALLOWABLE LOAD	COLUMN MAX. ALLOWABLE LOAD (kg)
500	UNISTT4141	743	0.87	3685
500	UNISTS4141	1958	0.5	9410
1000	UNISTT4141	350	3.5	2145
1000	UNISTS4141	980	2.01	8091
1500	UNISTT4141	248	7.87	1321
1500	UNISTS4141	655	4.49	6290
2000	UNISTT4141	186	13.99	936
2000	UNISTS4141	496	8.01	4420
2500	UNISTT4141	148	21.86	700
2500	UNISTS4141	395	12.52	2886
3000	UNISTT4141	125	31.46	N/R
3000	UNISTS4141	325	18.03	2003

LENGTHS

3 METRES / LENGTH

6 METRES / LENGTH

FINISHING

1 GALVANISING

2 HOT DIPPED GALVANIZING
(BS:EN:ISO1461 (2009), BS 729)

3 304 STAINLESS STEEL

4 316 STAINLESS STEEL

UNISTRUT CHANNELS ACCESSORIES

CABLE SUPPORT SYSTEM

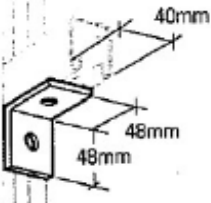
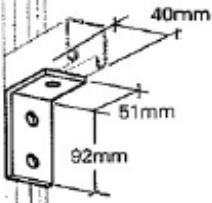
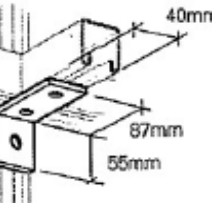
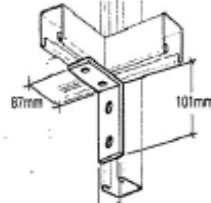
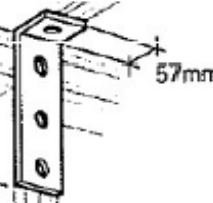
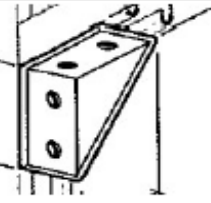
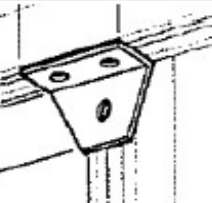
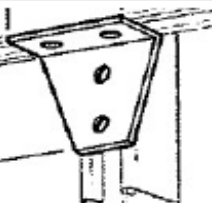
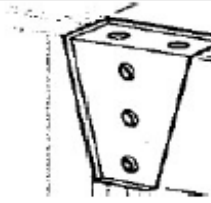
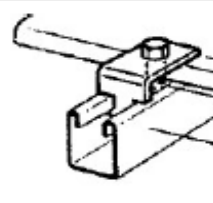
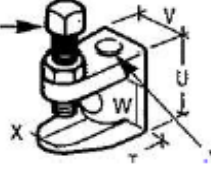
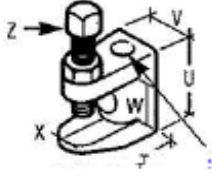
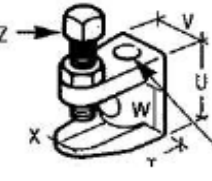
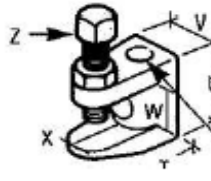
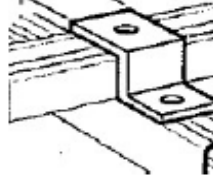
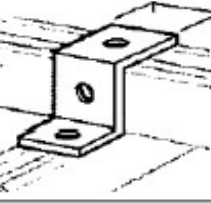
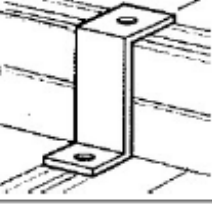
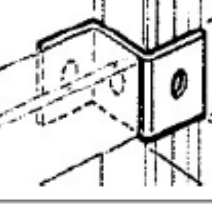
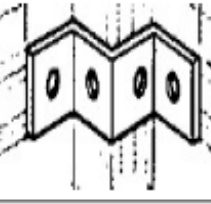
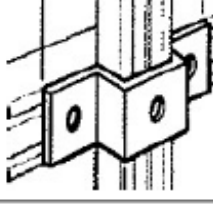
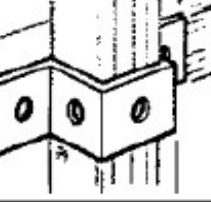
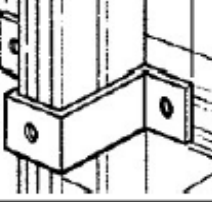
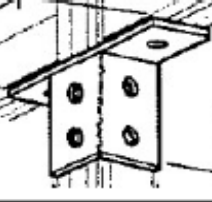
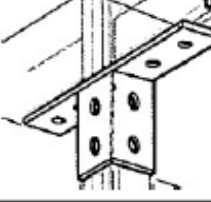
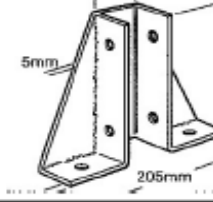
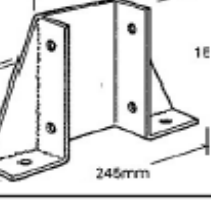
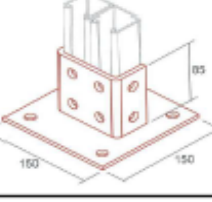
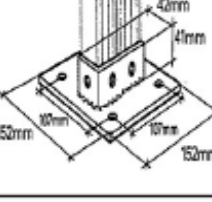
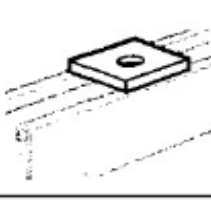
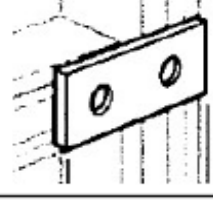
				
AB01/ ZWA200	AB03/ ZWA203	AB05/ ZWA204	AB06/ ZWA205	AB07/ ZWA206
UNISTRUT- ANGLE BRACKET	UNISTRUT- ANGLE BRACKET	UNISTRUT- ANGLE BRACKET	UNISTRUT- ANGLE BRACKET	UNISTRUT- ANGLE BRACKET
				
AB08/ ZWA207	AB09	AB10/ ZWA209	AB11	BC75/ ZTA605
UNISTRUT- ANGLE BRACKET	UNISTRUT- ANGLE BRACKET	UNISTRUT- ANGLE BRACKET	UNISTRUT- ANGLE BRACKET	UNISTRUT - BEAM CLAMPS
				
BC81/ TKNM6	BC82/ TKNM8	BC83/ TKNM10	BC84/ TKNM12	CB50/ ZSA300
UNISTRUT - BEAM CLAMPS	UNISTRUT - BEAM CLAMPS	UNISTRUT - BEAM CLAMPS	UNISTRUT - BEAM CLAMPS	UNISTRUT - CANNEL BRACKET
				
CB51/ ZSA301	CB52/ ZSA302	CB53/ ZSA303	CB54	CB55/ ZUA401
UNISTRUT - CANNEL BRACKET	UNISTRUT - CANNEL BRACKET	UNISTRUT - CANNEL BRACKET	UNISTRUT - CANNEL BRACKET	UNISTRUT - CANNEL BRACKET
				
CB56/ ZUA400	CB57/ ZUA403	CB62/ ZZA702	CB63	FB63/ ZGA503
UNISTRUT - CANNEL BRACKET	UNISTRUT - CANNEL BRACKET	UNISTRUT - CANNEL BRACKET	UNISTRUT - CANNEL BRACKET	UNISTRUT - FLOOR BRACKET
				
FB64/ ZGA504	A159	FB72	FP31/ ZE100	FP32/ ZE102
UNISTRUT - FLOOR BRACKET	UNISTRUT - FLOOR BRACKET	UNISTRUT - FLOOR BRACKET	UNISTRUT-FLATPLATE BRACKET	UNISTRUT-FLATPLATE BRACKET

UNISTRUT CHANNELS ACCESSORIES

CABLE SUPPORT SYSTEM

				
FP33/ ZE103	FP34/ ZE104	FP36/ ZE107	FP37/ ZE109	FP38/ ZE108
UNISTRUT - FLATPLATE BRACKET	UNISTRUT - FLATPLATE BRACKET	UNISTRUT - FLATPLATE BRACKET	UNISTRUT - FLATPLATE BRACKET	UNISTRUT - FLATPLATE BRACKET
				
FP41/ ZE110	FP43	C' BRACKET	DROP-IN ANCHOR	FLAT WASHER
UNISTRUT - FLATPLATE BRACKET	UNISTRUT - FLATPLATE BRACKET	CBK	DRPANCH	FLTWASHER
				
HEXAGON HEAD BOLT	HEXAGON NUT	LONG NUT	SLEEVE ANCHOR	SPRING NUT
HEXBOLT	HEX-NUT	LNG-NUT	SLVANCH	SPR-NUT
				
TRUSS HEAD BOLT	THREADED ROD	WEDGE ANCHOR	WEDGE NUT	SPRING WASHER
TRHBOLT	THDRDOD	WDGANCH	WDG-NUT	SPRWASH
				
CF-1 WAY TERMINAL BOX	CF-1 WAY BOX W BACK HOLE	CF-2 WAY THROUGH BOX	CF-2 WAY ANGLE BOX	CF-3 WAY "T" BOX
CFA1WB	CFA1HB	CFA2IB	CFA2LB	CFA3TB
				
CF-4 WAY "X" BOX	CF-EXTENSION RING BOX	CF-INSPECTION ELBOW	CF-INSPECTION TEE	CF-CIRCULAR COVER
CFA4XB	CFAERB	CFAIEB	CFAITE	CFACOV

GRM MAGIC MESH CABLE TRAYS

CABLE SUPPORT SYSTEM – OBO BETTERMAN

MADE IN GERMANY

35mm SIDE HEIGHT

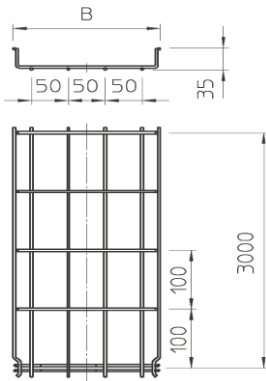
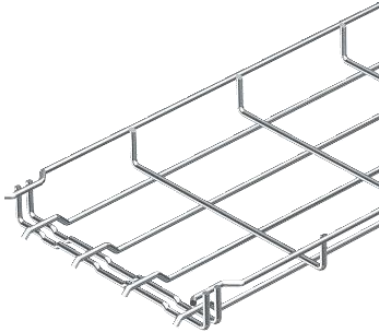

55mm SIDE HEIGHT

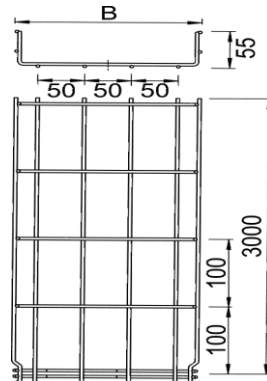
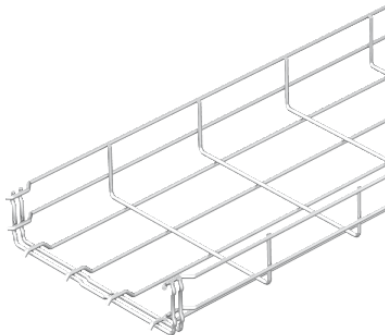

105mm SIDE HEIGHT

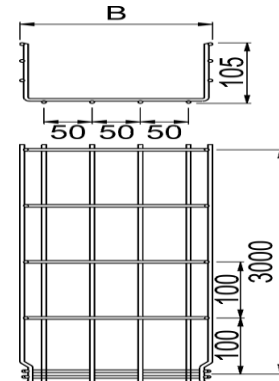
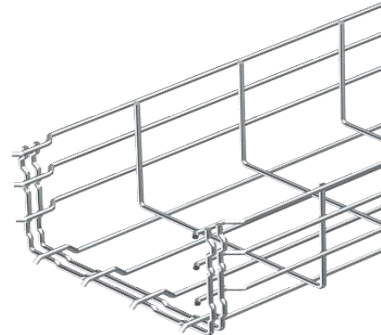

WIRE MESH TRAY IN 3 METRE LENGTHS

ELECTRO-GALVANISED	HOT-DIPPED GALVANISED	WIDTH	HEIGHT	WIRE DIA.
TMSTTEGI023539X	TMSTTHDG023539X	50	35	3.9
TMSTTEGI043539X	TMSTTHDG043539X	100		3.9
TMSTTEGI063539X	TMSTTHDG063539X	150		3.9
TMSTTEGI083539X	TMSTTHDG083539X	200		3.9
TMSTTEGI123548X	TMSTTHDG123548X	300		4.8
ELECTRO-GALVANISED	HOT-DIPPED GALVANISED	WIDTH	HEIGHT	WIRE DIA.
TMSTTEGI025539X	TMSTTHDG025539X	50	55	3.9
TMSTTEGI045539X	TMSTTHDG043539X	100		3.9
TMSTTEGI065539X	TMSTTHDG063539X	150		3.9
TMSTTEGI085539X	TMSTTHDG083539X	200		3.9
TMSTTEGI125548X	TMSTTHDG123548X	300		4.8
TMSTTEGI165548X	TMSTTHDG163548X	400		4.8
TMSTTEGI205548X	TMSTTHDG203548X	500		4.8
TMSTTEGI245548X	TMSTTHDG243548X	600	4.8	
ELECTRO-GALVANISED	HOT-DIPPED GALVANISED	WIDTH	HEIGHT	WIRE DIA.
TMSTTEGI04X539X	TMSTTHDG04X539X	100	105	3.9
TMSTTEGI06X539X	TMSTTHDG06X539X	150		3.9
TMSTTEGI08X548X	TMSTTHDG08X548X	200		4.8
TMSTTEGI12X548X	TMSTTHDG12X548X	300		4.8
TMSTTEGI16X548X	TMSTTHDG16X548X	400		4.8
TMSTTEGI20X548X	TMSTTHDG20X548X	500		4.8
TMSTTEGI24X548X	TMSTTHDG24X548X	600		4.8

*Limited stock of wire mesh trays is SUS 304 finish available, please email to enquire on inventory level.

GRM MAGIC MESH CABLE TRAYS

CABLE SUPPORT SYSTEM – OBO BETTERMAN

MADE IN GERMANY

JOINT CONNECTOR

including FRS M6 x 20 bolt with
flange nut

(PACK OF 20 PCS)

TMJCTEGI6016596 (EGI)

TMJCTHDG6016634 (HDG)



CORNER CONNECTOR

including FRS M6 x 12 bolt with flange nut
(PACK OF 20 PCS)

TMCCTEGI6016715 (EGI)

TMJCTHDG6016723 (HDG)



HOLD DOWN CLAMP

(7mm HOLE DIA)

(PACK OF 50 PCS)

TMHDCEGI6015263 (EGI)

TMHDCHDG6015271 (HDG)



IDENTIFICATION CLIP

(PACK OF 10)

TMIDCLIP6017712



END CAP

(PACK OF 500PCS)

TMECP386003750 (3.9mmD)

TMECP486003754 (4.8mmD)



EARTHING TERMINAL

M6 THREAD

(PACK OF 50 PCS)

TMTERBRA6404006



Additional trays and accessories may be available / subject to indent basis.
Kindly check with our sales representatives on your project requirements.

FORESIGHT METAL ENGRG PTE LTD

CABLE SUPPORT SYSTEM SPECIALIST & MORE

METAL CABLE SUPPORT SYSTEM

CONDUIT FITTING, PIPES & ACCESSORIES

EARTHING & LIGHTING PRODUCTS

WIRES

ECO-TECH @ SUNVIEW, 1 SUNVIEW ROAD #04-28, 29
SINGAPORE 627615

☎ 6294 8672

📠 6255 0087

💻 sales@foresight.com.sg

🌐 foresight.com.sg